



# Operation & Maintenance Manual

---

## Front Access System

Access System Models:

ADE008250 (Hitachi EH3500)

ADE008482 (Hitachi EH4000)

ADE014786 (Caterpillar 785B, 785C)

---



---

<b>1</b>	<b>GENERAL INFORMATION .....</b>	<b>1</b>	<b>6.1</b>	<b>REFERENCE MATERIAL .....</b>	<b>16</b>
<b>2</b>	<b>SAFETY .....</b>	<b>2</b>			
2.1	IMPORTANT SAFETY INFORMATION.....	2			
2.2	SAFETY SIGNS & LABELS .....	3			
<b>3</b>	<b>PRODUCT IDENTIFICATION INFORMATION...</b>	<b>4</b>			
3.1	FRONT ACCESS SYSTEM – ID PLATE .....	4			
<b>4</b>	<b>OPERATION SECTION.....</b>	<b>5</b>			
4.1	GENERAL INFORMATION .....	5			
4.2	CONTROLS & INDICATORS .....	6			
4.3	PARK BRAKE .....	8			
4.4	MACHINE OPERATION .....	8			
4.5	MOUNTING & DISMOUNTING .....	8			
4.5.1	<i>General Information .....</i>	<i>8</i>			
4.5.2	<i>Mounting Procedure.....</i>	<i>8</i>			
4.5.3	<i>Dismounting Procedure .....</i>	<i>9</i>			
4.6	EMERGENCY DISMOUNTING PROCEDURE.....	9			
4.7	DISMOUNTING PROCEDURE – PARTIAL OR COMPLETE ACCESS SYSTEM FAILURE .....	9			
4.7.1	<i>Hitachi EH3500 &amp; EH4000.....</i>	<i>9</i>			
4.7.2	<i>Caterpillar 785B &amp; 785C .....</i>	<i>9</i>			
<b>5</b>	<b>MAINTENANCE SECTION.....</b>	<b>11</b>			
5.1	GENERAL HAZARD INFORMATION.....	11			
5.1.1	<i>Crushing &amp; Cutting Prevention.....</i>	<i>11</i>			
5.2	MAINTENANCE INTERVAL - BEFORE USE .....	12			
5.2.1	<i>Walk-Around Inspection.....</i>	<i>12</i>			
5.3	MAINTENANCE INTERVAL - EVERY 1000 SERVICE HOURS OR 6 MONTHS.....	12			
5.3.1	<i>Bolts and Mounting Hardware.....</i>	<i>12</i>			
5.3.2	<i>Hydraulic System – Inspect .....</i>	<i>13</i>			
5.3.3	<i>Lower Stair Pivot Points – Lubricate .....</i>	<i>13</i>			
5.3.4	<i>Emergency Egress Gate.....</i>	<i>13</i>			
5.4	EVERY 4000 SERVICE HOURS OR 2 YEARS...13	13			
5.4.1	<i>Hydraulic Oil Compartment.....</i>	<i>15</i>			
<b>6</b>	<b>LITERATURE REFERENCE MATERIALS .....</b>	<b>16</b>			

---

---

# 1 General Information

This guideline provides all the necessary information to operate and maintain the access system fitted to the Hitachi EH3500 & EH4000 and CAT 785C dump trucks. Use this information in-conjunction with Hitachi and Caterpillar information where specified.

For part replacement items refer to the Parts Manual for parts replacement details for the front access system fitted to your machine.

Whenever a question arises regarding the information contained within this manual please consult Australian Diversified Engineering Pty Ltd for the latest available information. Selected manuals may be found at [www.ade.net.au](http://www.ade.net.au) containing the most up to date information for the product.

---

## 2 Safety

### 2.1 Important Safety Information

Safety precautions and warnings may be listed in this manual and applied to the product (supplied by Australian Diversified Engineering) in the form of safety signs and labels.

Safety signs and labels may be positioned on specific parts of the product to draw attention to objects and situations affecting health and safety. If these hazard warnings are not heeded, bodily injury or death may occur to you or other persons.

The severity of the consequences of the hazard may be easily identified by the alert symbol at the top of the label.

The **DANGER** alert symbol is used to warn of a hazardous situation that is likely to be life threatening. Ensure you are aware of situations and locations on the product displaying this alert symbol.



The **WARNING** alert symbol is used to warn of a hazardous situation that is not likely to be life threatening. Ensure you are aware of situations and locations on the product displaying this alert symbol.



The wording given underneath the **DANGER** or **WARNING** alert symbol will warn of the hazard, the consequences of the hazard followed by information on how to prevent the hazardous situation from occurring.

Some signs placed on the product or machine (which do not contain a safety alert or symbol such as Danger

or Warning) are to indicate that an instruction must be carried out. The label will contain black text on a white background. Read and obey the information contained on these labels.

The **NOTICE** heading may be contained within this manual and is used to highlight or alert to certain aspects of the product. Commonly the **NOTICE** heading is used to highlight the weight of an object or some other form of specific information applicable to the task to be performed.

Australian Diversified Engineering cannot anticipate all possible hazards. For instance, some hazards may be specific to your workplace or the equipment or tool you employ to complete the task.

Plan the job before proceeding. Planning before commencement of the job will help identify possible hazards in the job procedure which can be eliminated or controlled.

Be aware of unintended movement when assembling and disassembling components and ensure machines are isolated in accordance with workplace and supplier instructions when performing maintenance.

Ensure items are installed properly and are not damaged during the installation procedure or during operation of the machine. If damaged or installed incorrectly the product may not operate and perform as intended and may be made unsafe as a result. Ensure all items are repaired or replaced and care is taken when installing items on the machine.

Operate and maintain the machine in accordance with procedures specified by the original equipment manufacturer and information contained within this manual.

## 2.2 Safety Signs & Labels

There are several specific safety signs specific to the access system. Their location and description of the hazard are reviewed in this section. Make sure that you can read all safety signs. You must replace a label if it is damaged, missing or cannot be read. If a label is on a part that is replaced, make sure a new label is installed on the replaced part. Contact Australian Diversified Engineering for replacement labels.

**ACCESS SYSTEM**

**FOR SAFE OPERATION OF THE ACCESS SYSTEM ENSURE:**

- ALL PERSONNEL ARE CLEAR OF ACCESS SYSTEM BEFORE OPERATING CONTROLS.
- ACCESS SYSTEM IS IN THE FULLY LOWERED POSITION BEFORE USE.

**ADE004144**

	<p><b>WARNING</b></p> <p><b>READ OPERATION &amp; MAINTENANCE MANUAL SUPPLEMENT BEFORE OPERATING CONTROLS</b></p>
---	--

ADDITIONAL CONTROLS AND COMPONENTS HAVE BEEN FITTED TO THIS MACHINE FOR OPERATION & MAINTENANCE OF A FIXED, POWERED OR MANUAL ACCESS SYSTEM.

BEFORE OPERATING OR PERFORMING MAINTENANCE ON THIS MACHINE ENSURE THAT THE OPERATION & MAINTENANCE MANUAL SUPPLIED BY AUSTRALIAN DIVERSIFIED ENGINEERING FOR THIS MACHINE HAS BEEN READ AND UNDERSTOOD (IN CONJUNCTION WITH ANY OEM OPERATION & MAINTENANCE INSTRUCTIONS). ADE006725

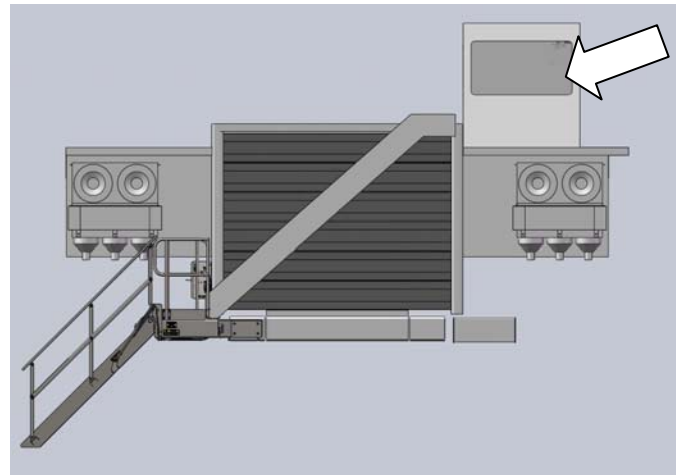

These signs are located inside the cab adjacent to the access system controls

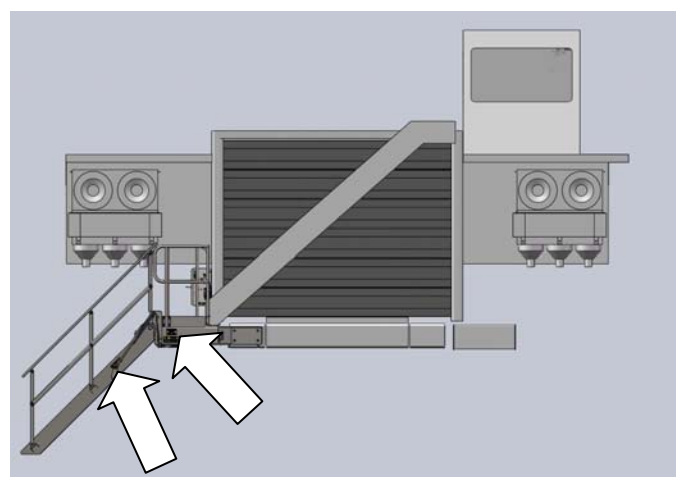

These signs are located on the front of the access system

---

### 3 Product Identification Information

#### 3.1 Front Access System – ID Plate

An ID plate has been fitted to the front access system which indicates information such as the model number, date of manufacture and the serial number. Refer to the plate fitted to each machine for specific details.

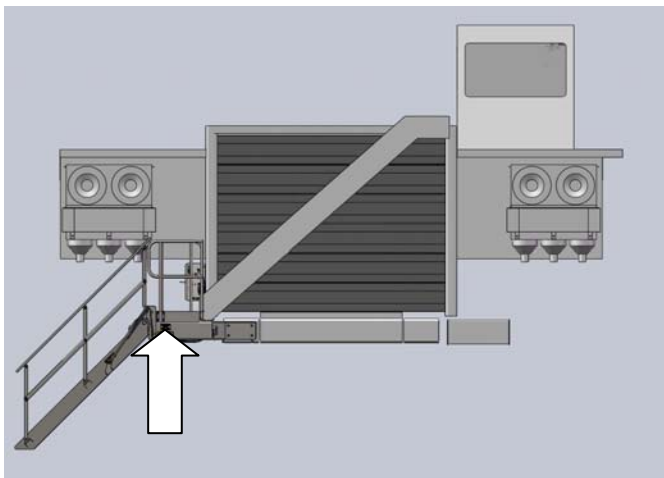

ID plate for the access system

---

## 4 Operation Section

### 4.1 General Information

The access system is a single stage electric-over-hydraulic folding system fitted to the front of the truck. The access system utilises a 24V DC hydraulic power pack coupled with a manifold of hydraulic sequence valves and pilot operated check valves to drive and control the hydraulic cylinders that raise and lower the access system.

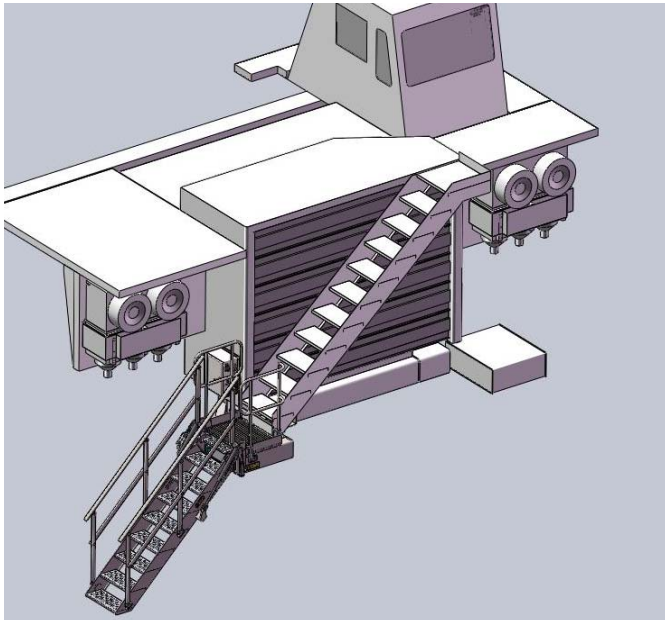

Front access system in the lowered position for mounting and dismounting

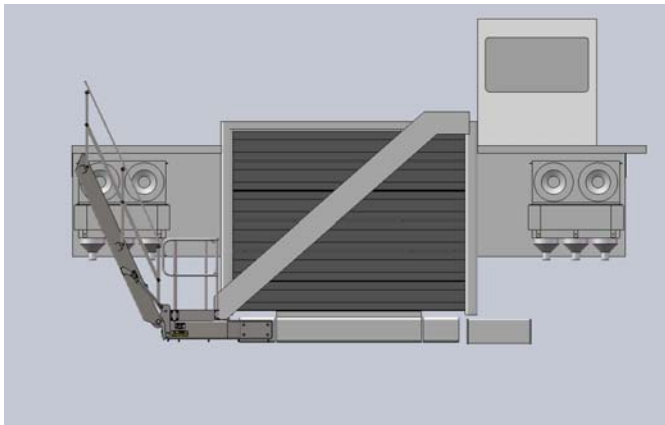

Front access system in the raised position for machine operation

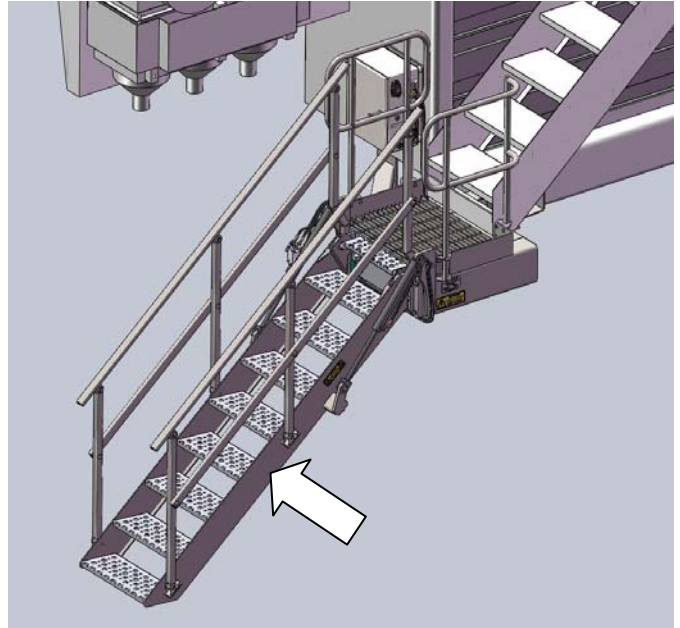

Hydraulic powered lower stair assembly

4.2 Controls & Indicators

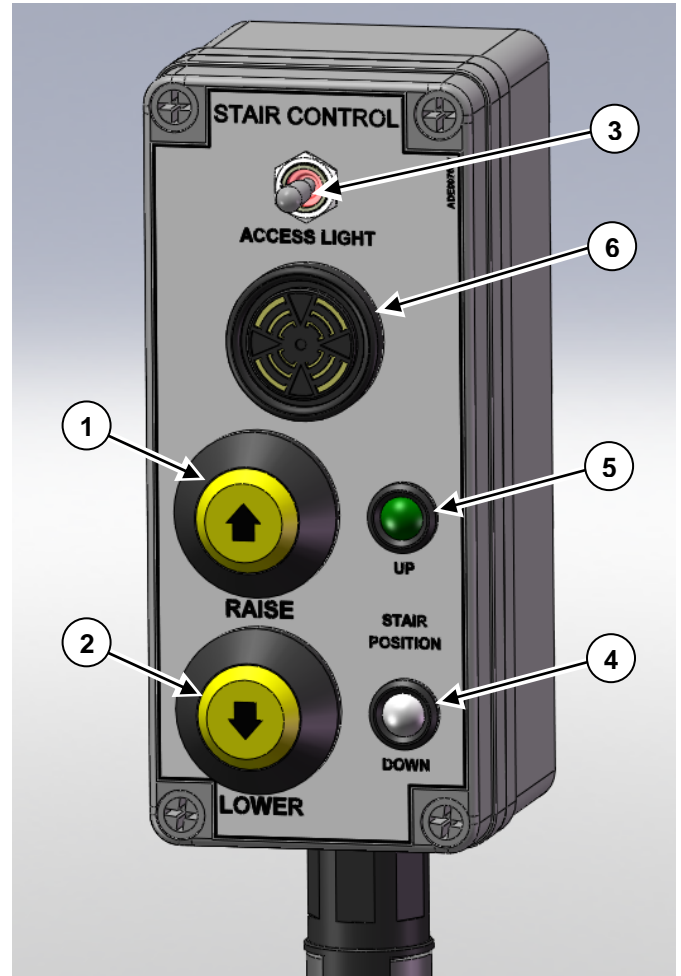
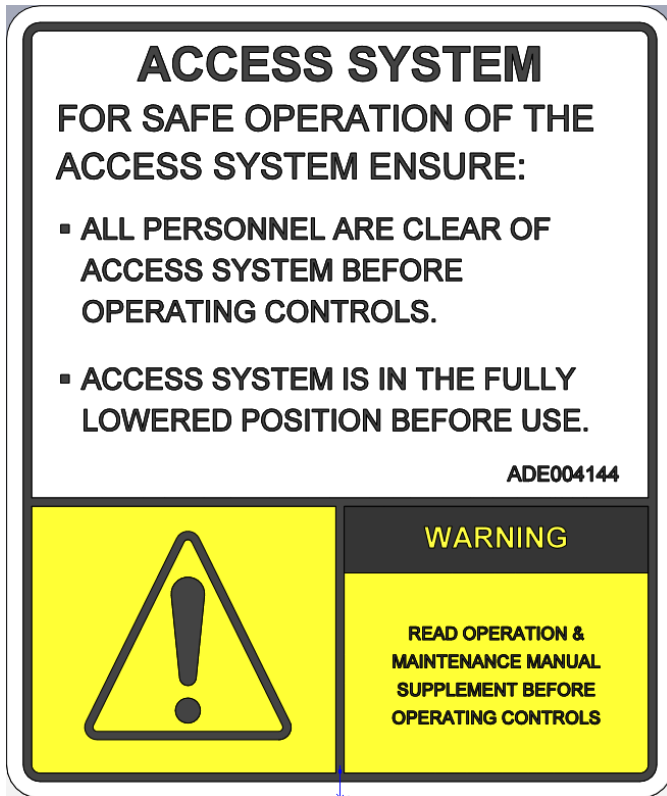

Cab control panel

Controls for raising and lowering the access system are located inside the cab and at ground level.

The controls for the access system include:

- (1) Raise Control
- (2) Lower Control
- (3) Access Lights Switch (where fitted)
- (4) "UP" - Visual Indicator
- (5) "DOWN" - Visual Indicator
- (6) Cab Mounted Audible Alarm
- (7) Hydraulics Cabinet Audible Alarm
- (8) Check Mirror (where fitted)

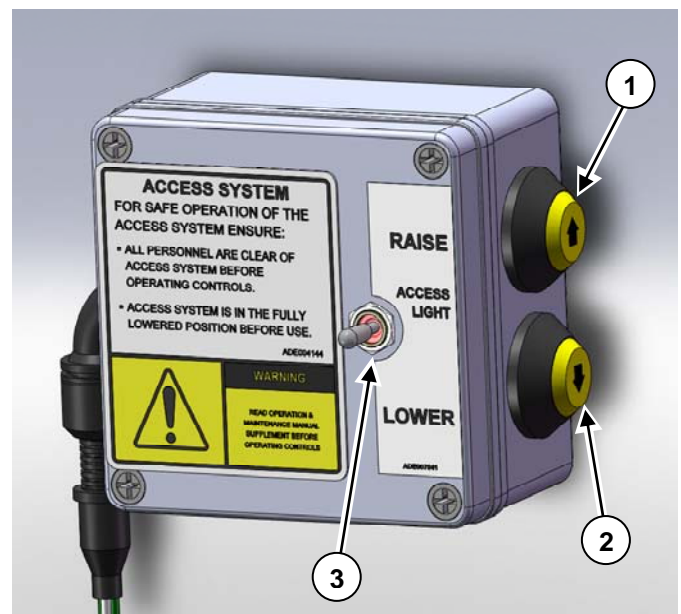

Ground level control panel

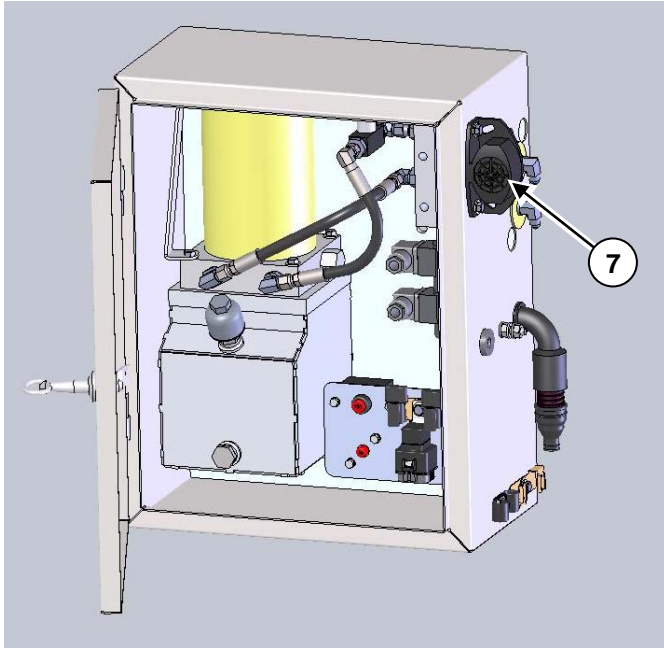

External audible alarm (7) mounted to the access system hydraulics cabinet adjacent to the access system

### (1) & (2) Raise and Lower Controls

Depress the required button to either raise or lower the access system.

The access controls utilised on this machine are of the momentary push button type. This requires the operator to press the button for the duration of raising or lowering. If the button is released at any point in the system operation then power will be cut immediately and the access system will cease to move (commonly known as 'dead-man' controls).

### (3) Access Lights Switch (where fitted)

Use this switch to activate the access system light mounted on the radiator cowl, illuminating the access system in low light conditions. Only Caterpillar models are equipped with an access system light, access system lighting on Hitachi models is via the standard switch.

### (4) UP Visual Indicator

Constant green illumination when the access system is the raised position. The access system must be in this position for machine operation.

### (5) DOWN Visual Indicator

- a) Illuminates green when the access system is in the lowered position.
- b) Illuminates red when the park brake is released and the stair is not in the raised position. Sounding of the in-cab audible alarm will occur when the down visual indicator illuminates red.

Refer to Section **4.3 Park Brake** for additional information on the in-cab control panel warnings.

### (6) & (7) Audible Alarms

Audible alarms are mounted on the cab control panel and externally on the hydraulics cabinet. When the access system is being raised or lowered the hydraulics cabinet mounted alarm will sound. When the park brake is released and the ladder is in the lowered position the alarm on the cab control panel will sound.

Refer to Section **4.3 Park Brake** for additional information on the cab control panel warnings.

---

## (8) Check Mirror (where fitted)

Caterpillar models are equipped with a check mirror, to assist the operator in ensuring that the access system is free of personnel.

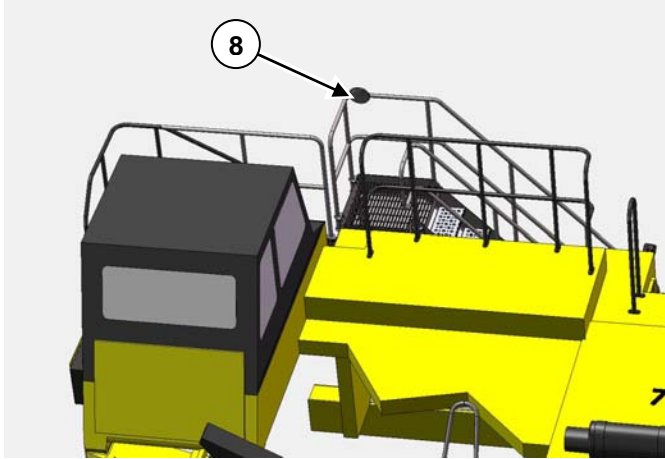

## 4.3 Park Brake

When the park brake is released and the access system is not in the raised position the cab audible alarm (6) will sound and the visual alarm (5) will activate. Do not continue to operate the machine as damage to the access system may occur.

Releasing of the park brake will not automatically raise the access system. Ladder raise and lower is via the controls on the cab and ground level control panels only.

## 4.4 Machine Operation

The in-cab audible alarm (6) will sound if the access system has lowered due to a fault during machine operation (ie. in circumstances where the machine park brake is not applied). Illumination of the stair down light will also occur. If audible and visual alarms are activated do not continue to operate the machine as damage to the access system may occur.

## 4.5 Mounting & Dismounting

### 4.5.1 General Information

- Inspect, and when necessary, clean and have repairs made to steps and handrails before mounting and dismounting.
- Ensure the access system is in the fully lowered position before accessing.
- Maintain a three-point contact (two feet and one hand or one foot and two hands contact) with the steps and handholds.
- Ensure the machine is in a safe state before mounting and dismounting the machine via the access system.

### 4.5.2 Mounting Procedure

Do not attempt to access the machine whilst moving or whilst another operator is in the machine and the engine running. Refer to applicable mine site regulations for approaching machines. If not governed by mine site regulation ensure two-way radio contact has been made with the operator prior to approaching the machine.

To mount the machine using the access system:

1. Ensure that the battery disconnect switch is in the connected position. Refer to the machine specific Hitachi or Caterpillar Operation and Maintenance Manual for location and operation of the battery disconnect switch.
2. Utilise the appropriate access lighting and switching if mounting in low light conditions.
3. With the access system in the lowered position mount the access system. Maintain three points of contact whilst on the access system. If the access system is not lowered operate the ground level switch to completely lower the system.
4. Enter the cab and ensuring that the access system is free from personnel, use the in-cab controls to

---

raise the ladder to the stowed position. Once stowed correctly the green 'UP' visual indicator on the in-cab control panel will be illuminated.

5. Start and operate the machine in accordance with procedures outlined in the Hitachi or Caterpillar Operation and Maintenance Manual as well as applicable mine site instructions.

#### 4.5.3 Dismounting Procedure

To dismount the machine using the access system:

1. Stop the machine in accordance with procedures outlined in the machine specific Hitachi or Caterpillar Operation and Maintenance Manual as well as applicable mine site instructions.
2. Ensuring that the ground area is free from personnel use the lower button on the in-cab control panel to completely lower the access system.
3. Utilise the standard access light and switching if mounting in low light conditions.
4. Exit the cab.
5. Visually inspect to ensure the access system has lowered and the handrails have raised to the upright position.
6. Dismount the machine maintaining three point contact at all times.
7. If required raise the access system to the stowed position using the ground level controls.

#### 4.6 Emergency Dismounting Procedure

Refer to further information on alternate exits (if available) in the machine specific Operation & Maintenance Manual.

#### 4.7 Dismounting Procedure – Partial or Complete Access System Failure

##### 4.7.1 Hitachi EH3500 & EH4000

To dismount the machine (without the use of the access system) in the event of partial or complete access system failure:

1. Stop the machine in accordance with procedures outlined in the Hitachi Operation and Maintenance Manual as well as applicable mine site instructions.
2. Dismount the machine via the alternate egress system.
3. Ensure the ladder failure is investigated and fault/s repaired.

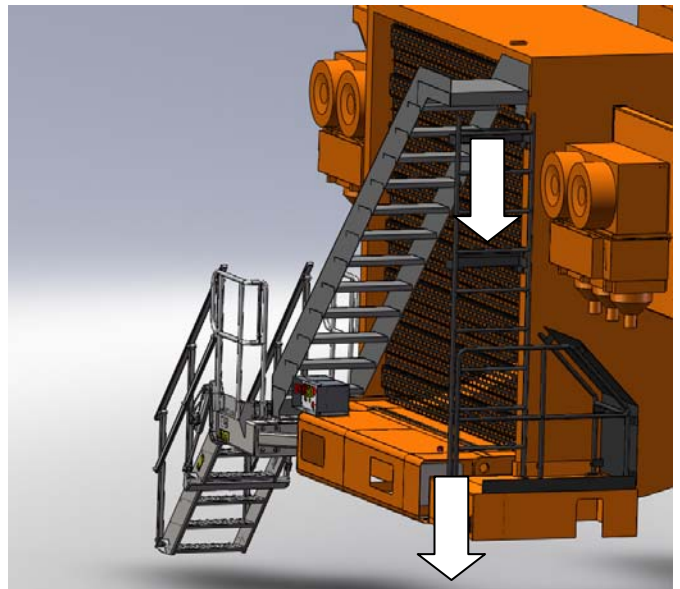

Hitachi EH3500 & EH4000 - Exit the cab then dismount to the bumper via the left side egress ladder, then exit to ground level via the bumper ladder.

##### 4.7.2 Caterpillar 785B & 785C

To dismount the machine (without the use of the access system) in the event of partial or complete access system failure or to promptly egress the machine in an emergency situation:

1. Stop the machine in accordance with procedures outlined in the Caterpillar Operation and

---

Maintenance Manual as well as applicable mine site instructions.

2. Ensuring the park brake is applied; exit the cab and dismount to bumper level using the right side standard machine egress ladder.
3. From the bumper use the latch to open the gate and egress the machine to ground level via the bumper ladder.
4. Ensure the ladder failure is investigated and fault/s repaired.

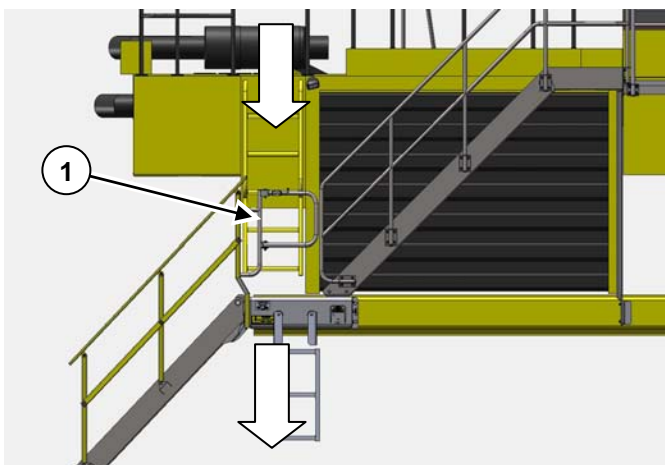

Caterpillar 785B & 785C - Exit the cab then dismount to the bumper via the right side egress ladder to the access gate (1)

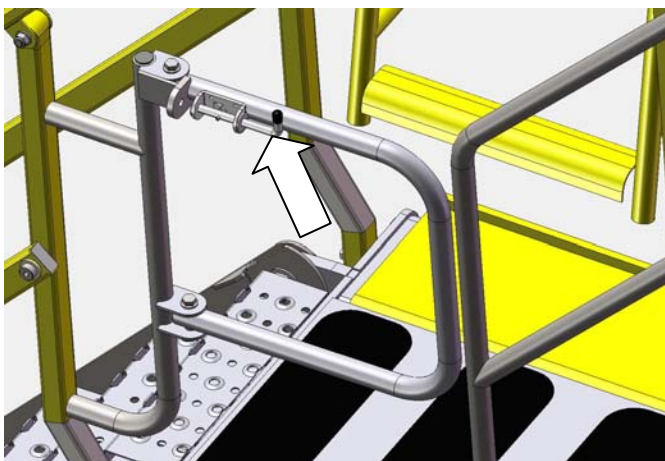

Caterpillar 785B & 785C - From the bumper use the latch to open the gate and exit to ground level via the bumper ladder

---

## 5 Maintenance Section

### 5.1.1 Crushing & Cutting Prevention

#### **WARNING**

Unintended machine movement may result in personal injury or death. Before performing maintenance on this machine ensure it has been isolated in accordance with mine site and manufacturer procedures and a Do Not Start Tag has been applied in the appropriate location on the machine.

#### **WARNING**

Disconnection of hoses and removal of supporting pins and bolts of the access system may result in unintended machine movement and/or release of stored energy. Personal injury or death may result. Before disassembly of any components of the access system ensure that stored energy has been relieved and components are chocked/blocked to prevent unintended movement.

#### **NOTICE**

You must read and understand the warnings and instructions contained in the Safety Section of this manual, before performing any maintenance procedures.

#### **WARNING**

Disconnection of hoses and removal of supporting pins and bolts of the access system may result in unintended machine movement and/or release of stored energy. Personal injury or death may result. Before disassembly of any components of the access system ensure that stored energy has been relieved and components are chocked/blocked to prevent unintended movement.

- Support equipment and attachments properly when working beneath them. Never attempt adjustments while the machine is moving or the engine is running unless otherwise specified.
- Stay clear of all rotating and moving parts.

### 5.1 General Hazard Information

Perform all maintenance unless otherwise specified as follows:

- The machine parked on level ground.
- The park brake engaged.
- The engine stopped.
- The start switch key off and the key removed.
- All disconnect switches locked out and a Do Not Start Tag applied.
- All other external energy sources disconnected from the machine.

## 5.2 When Required

### 5.2.1 Circuit Breaker - Reset

The electrical system for the access system contains a 120 Amp Main Circuit Breaker (1) and a 10 Amp Switching Circuit Breaker (2), located inside the hydraulics cabinet. There is also a 120 Amp circuit breaker (3) mounted inside the battery box on the machine. Reset the circuit breakers when required. If a circuit breaker continually trips, have the circuit checked.

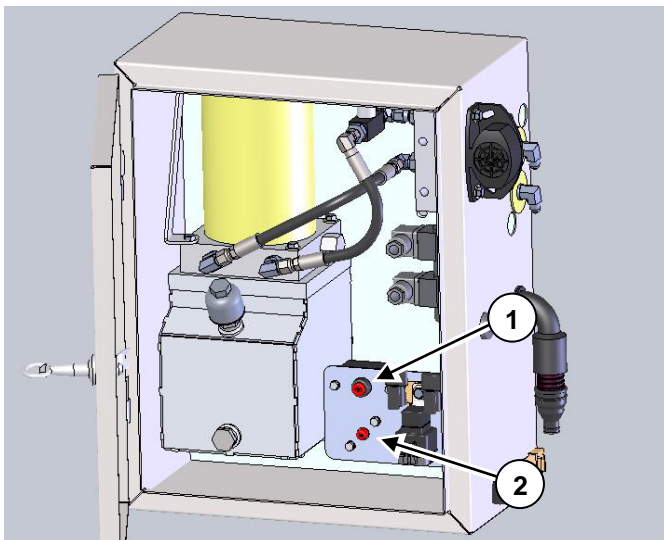

Circuit breakers located in hydraulics cabinet

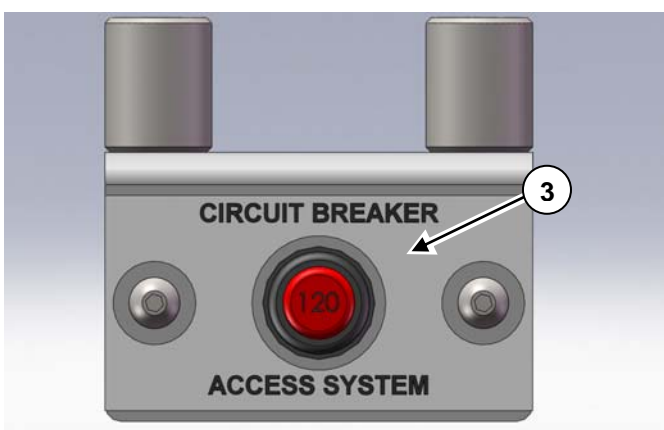

120 Amp circuit breaker

## 5.3 Maintenance Interval - Before Use

### 5.3.1 Walk-Around Inspection

Perform a walk-around inspection on the machine prior to operation.

- Ensure all steps are clean and free from debris.
- Visually inspect components for damage and wear and tear. Have any damaged or missing components repaired or replaced.
- Visually inspect all hoses, fittings and hose clamps for security, damage, deterioration and leaks.
- Check to ensure that the access system light is in working condition.
- Ensure the check mirror is clean.
- Visually inspect all switches of the system. Ensure all visual indicators are operational.
- Check to ensure all labels can be read and are visible in conjunction with the Safety Signs and Labels section of this manual. Replace label/s if they cannot be read or are missing.
- Ensure the bumper mounted audible alarm operates in conjunction with the access system.

## 5.4 Maintenance Interval - Every 250 Service Hours or Monthly

### 5.4.1 Hydraulics Cabinet Oil Level - Check

Check the level of the hydraulic oil compartment. Top-up if required, referring to section **Hydraulic Oil Compartment** in the Maintenance Section of this manual.

## 5.5 Maintenance Interval - Every 1000 Service Hours or 6 Months

### 5.5.1 Bolts and Mounting Hardware

Check the tightness of all bolts fitted to the access systems. This includes checking the handrails, access platforms and their mountings.

### 5.5.2 Hydraulic System – Inspect

Inspect all lines, hoses fittings, hose clamps and cylinders for damage and deterioration. If there are any damaged, missing or leaking parts ensure that they are replaced. Check to ensure the mountings for the hydraulic cabinet are secure.

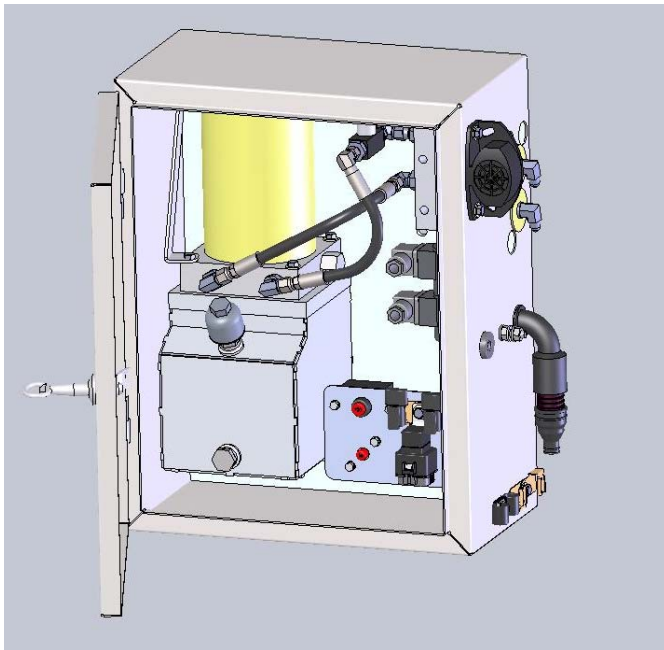

Hydraulics cabinet

Open the hydraulics cabinet lid and inspect all hoses and fittings for leaks. Replace any items as required. Hydraulic systems and components should be serviced only in consultation with Australian Diversified Engineering.

### 5.5.3 Lower Stair Pivot Points – Lubricate

Lubricate the main pivot points of the access system via the grease fittings with good quality molybdenum based grease. There are two grease fittings for the access system.

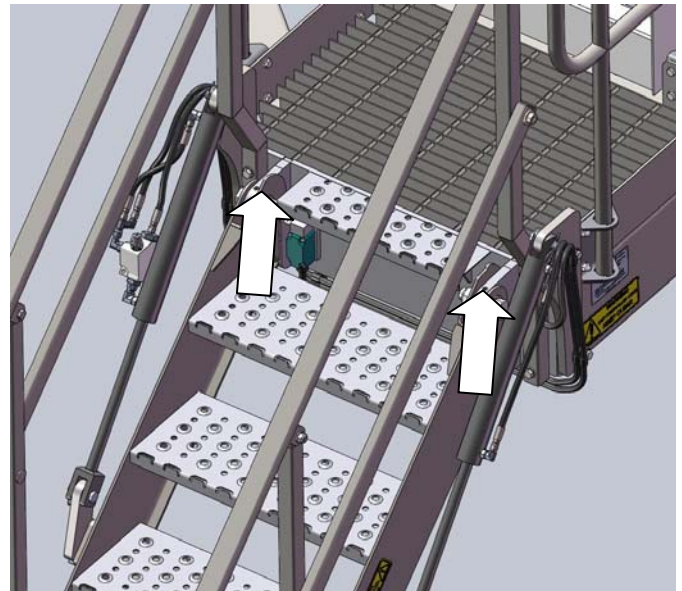

Two grease points for the lower stair assembly

### 5.5.4 Emergency Egress Gate

If equipped, ensure the emergency egress gate at bumper level can be opened freely and the latching mechanism is secure. Repair or replace if gate cannot be opened or latched properly.

5.6 Maintenance Interval - Every 2000 Service Hours or 1 Year

5.6.1 Handrail Pivot Points - Inspect/Replace

Inspect the handrail upper pivot points (1), middle pivot points (2), and lower pivot points (3) for excessive wear. If bushings (a), (b) or (c) are missing or worn, ensure that they are replaced.

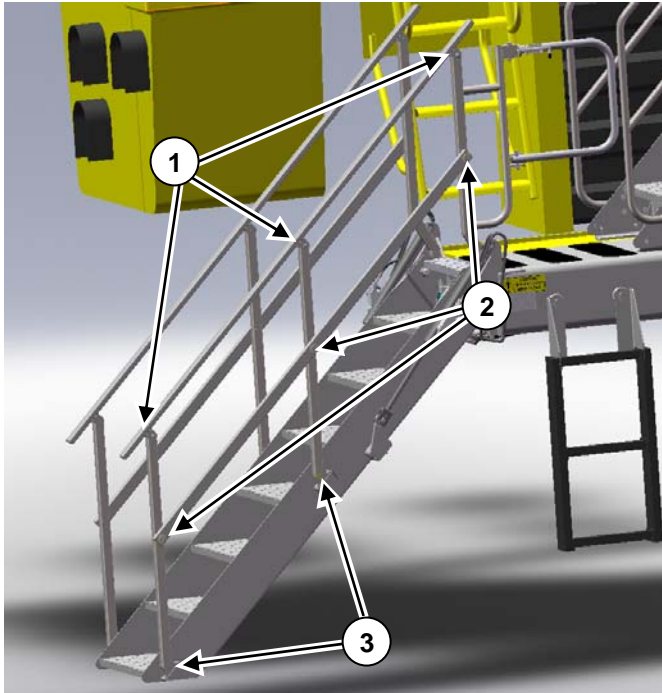

Handrail pivot points

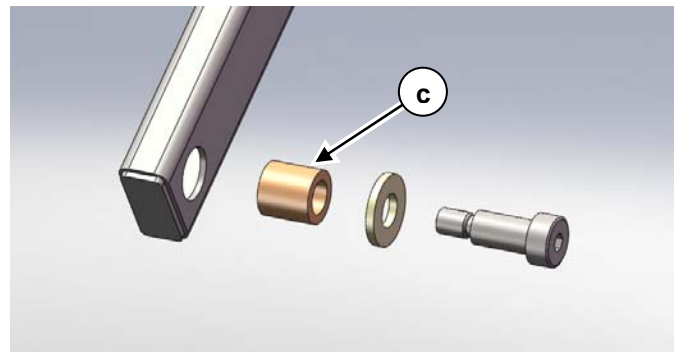

Middle handrail pivot point assembly (2), including bushing (c)

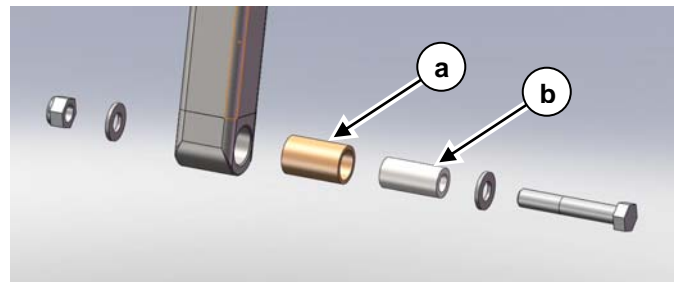

Lower handrail pivot point assembly (3), including bushings (a) and (b)

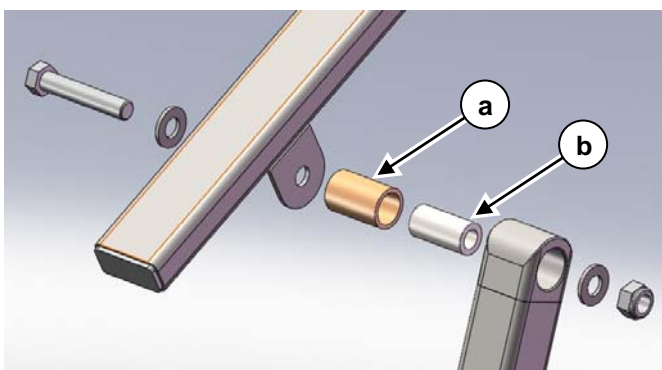

Upper handrail pivot point assembly (1), including bushings (a) and (b)

---

## 5.7 Every 4000 Service Hours or 2 Years

### 5.7.1 Hydraulic Oil Compartment

Replace the hydraulic oil every 24 months / 2 years in consultation with Australian Diversified Engineering. Use only Castrol Hyspin AWH-M ISO Viscosity grade 68 oil or an equivalent specification oil in the hydraulic system.

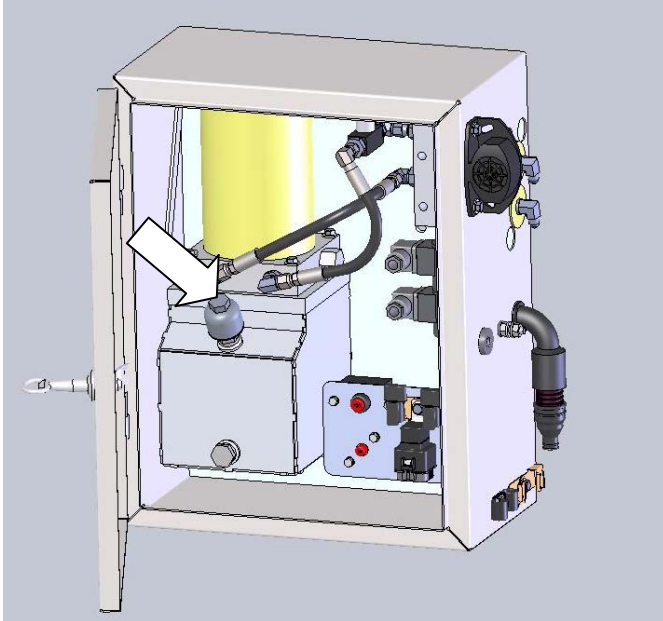

Fill point cap for the hydraulic oil compartment

---

## 6 Literature Reference Materials

### 6.1 Reference Material

Machine specific Hitachi or Caterpillar Operation and Maintenance Manuals.